

**Multifunctional  
reference meter  
Energomonitor-61850**

User Manual

MC3.055.501 UM

2019

## Contents

<b>INTRODUCTION .....</b>	<b>3</b>
<b>1. SAFETY REQUIREMENTS.....</b>	<b>3</b>
<b>2. DESCRIPTION .....</b>	<b>3</b>
2.1. APPLICATION .....	3
2.2 MODIFICATIONS .....	3
2.3 DESCRIPTION .....	4
2.4 DESIGN AND OPERATION PRINCIPLE .....	7
2.4.1 <i>Basic functional modules</i> .....	7
2.4.2 <i>Synchronization Unit</i> .....	8
2.4.3 <i>Interface of the External Control Terminal</i> .....	9
<b>3. PREPARING FOR OPERATION .....</b>	<b>10</b>
3.1. NOTES ON OPERATING CONDITIONS .....	10
3.2. UNPACKING .....	10
3.3. MAKING CONNECTIONS .....	10
<b>4. OPERATION .....</b>	<b>11</b>
4.1. TURNING ON .....	11
4.2. CONFIGURING THE INSTRUMENT .....	11
4.3 VERIFICATION OF CONVENTIONAL VOLTAGE TRANSFORMERS .....	11
4.4 VERIFICATION OF CONVENTIONAL CURRENT TRANSFORMERS.....	13
4.5. VERIFICATION OF DIGITAL VOLTAGE TRANSFORMERS .....	14
4.5.1 <i>Comparing a 61850-9-2 signal from the VT under test with an analogue signal from the reference transformer</i> .....	14
4.6. VERIFICATION OF DIGITAL CURRENT TRANSFORMERS .....	15
4.6.1 <i>Comparing a 61850-9-2 signal from the CT under test with an analogue signal from the reference transformer</i> .....	15
<b>APPENDIX A. SPECIFICATIONS .....</b>	<b>16</b>
<b>APPENDIX B. SCOPE OF SUPPLY .....</b>	<b>19</b>

## Introduction

This document describes the reference standard meters of Energomonitor-61850 type (the instrument below).

### 1. Safety requirements

The instrument is included in the product range of instruments compliant with the requirements of “Interbranch Rules for Labor Safety When Operating Electrical Systems”

With respect to electric shock protection, the instrument relates to class I equipment as stated in IEC 61140:2009 (“Protection against electric shock. Common aspects for installation and equipment”).

The instrument is compliant with the safety requirements of IEC 61010-1:2001 (“Safety requirements for electrical equipment for measurement, control and laboratory use”):

- Insulation category: basic
- Measurement category: III
- Degree of protection against pollution: 1

Protection provided by the enclosure: IP20 (according to IEC 60259).

### 2. Description

#### 2.1. Application

The reference meter Energomonitor-61850:

- Measures currents and voltages and converts them into digital streams of instantaneous values according to IEC 61859-9-2
- Calculates ratio and phase errors of current and voltage scaling converters (conventional, electronic and digital instrument transformers) with either analog outputs or digital (Sampled Value) outputs according to IEC 61859-9-2
- Determines accuracy characteristics of SAMU (Stand-Alone Merging Units) with analog current and voltage inputs (including IEC 61869-13 inputs)
- Measures active electrical power in three-phase and single-phase circuits
- Measures electrical energy in three-phase and single-phase circuits
- Performs AC current and voltage measurements

The EM-61850 can work in combination with a PC or as part of a test system used for testing, verification and calibration of:

- Instrument voltage (VTs) and current (CTs) transformers
- Electronic instrument voltage (EVTs) and current (ECTs) transformers and Merging Units with digital outputs according to IEC 61850-9-2
- Single-phase or three-phase wattmeters and active power converters
- Multimeters and active/reactive power meters with digital outputs according to IEC 61850-9-2
- Phase meters, frequency meters, voltmeters, ampere meters and current / voltage measuring converters working within the range of commercial frequencies

#### 2.2 Modifications

The Energomonitor-61850 comes in several modifications differing in design, accuracy, rated frequency, and functionality. The name of the reference meter consists of the instrument name (Energomonitor-61850) and modification name that reflects the available set functions:

Energomonitor-61850 X-X-XX-X

1 2 3 4

1 – Modification in terms of design

- S – Stationary (19” rack mount or desktop versions)
  - P – Portable
  - 2 – Modification in terms of accuracy
    - 02 – Accuracy characteristics as stated in Tables 3.1, 3.3, 3.5, and 3.7 of the Equipment Certificate MC3.055.501 EC
    - 05 – Accuracy characteristics as stated in Tables 3.2, 3.4, 3.6, and 3.7 of the Equipment Certificate MC3.055.501 EC
  - 3 – Modification in terms of additional functions available
    - 00 – No additional functions
    - 01 – Comparator function (calibration of current and voltage instrument transformers with use of the external switchgear unit CTCS)
  - 4 – Modification in terms of rated frequency ( $f_{NOM}$ )
    - 50 –  $f_{NOM} = 50$  Hz in the range from 42.5 to 57.5 Hz
    - 60 –  $f_{NOM} = 60$  Hz in the range from 51 to 69 Hz
- Nominal (rated) values of current ( $I_N$ ): 0.1; 0.25; 0.5; 1; 2.5; 5; 10; 25; 50, and 100 A  
Nominal (rated) values of voltage ( $U_N$ ): 1, 2, 5, 10, 30, 60, 120, 240, 480, and 800 V

### 2.3 Description

Fig. 2.1a and 2.1b show the front and rear panels of the Energomonitor-61850-S (Stationary).

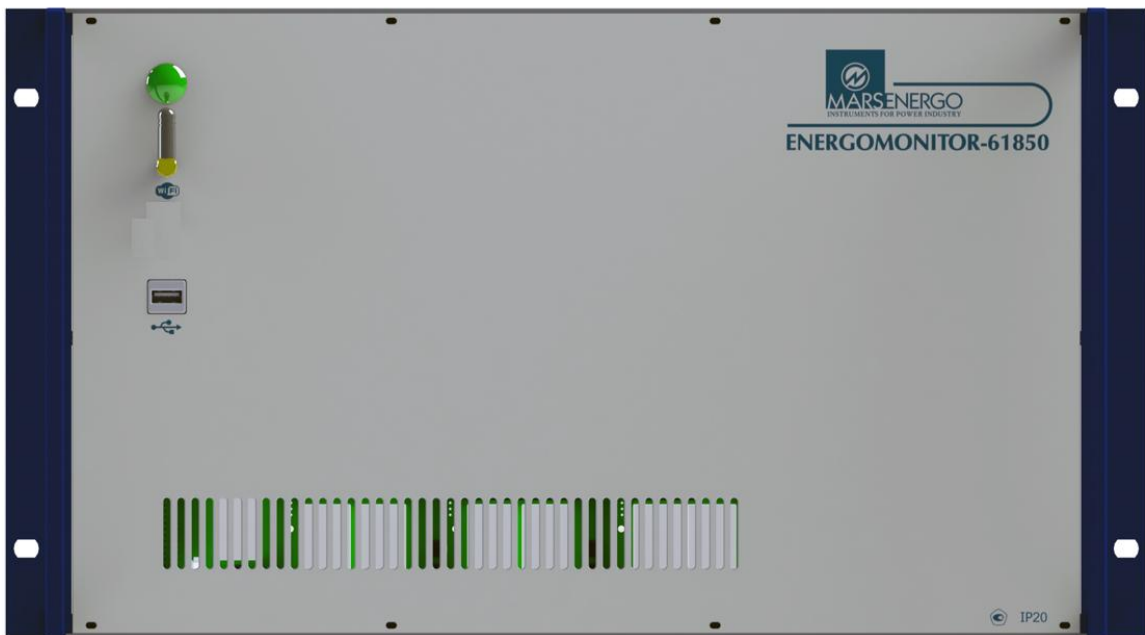

**Fig. 2.1a** – Front panel of the stationary version



- Current input – the terminals for connection to the 12A and 100A phase current measurement inputs
- Potential input – the terminals for connection to the voltage measurement inputs
- Ext – the input for accepting digital streams (shown without a SFP/- adapter)
- Out/Aux – the connector for outputting digital streams / auxiliary input
- Control – the connector of the External Control Terminal (Ethernet)
- PTP – the input/output sync connector (according to PTPv2 protocol)
- CTCS, Current – the terminal for connecting the external switchgear unit CTCS (for calibration of conventional CTs)
- PPS in /PPS out – the input/output sync connector (1 PPS)
- Fout – the frequency output (TM and TTL)
- CLKout /CLKin – the input/output connector 5/10/20 MHz
- Fin – the frequency input
- SH, USB – service connectors

**Fig. 2.1b** – Rear panel of the stationary version

Fig. 2.2 shows the front panel of the Energomonitor-61850-P (Portable).



- Current input – the terminals for connection to the 12A and 100A phase current measurement inputs
- Potential input – the terminals for connection to the voltage measurement inputs
- Ext – the input for accepting digital streams (shown without a SFP/- adapter)
- Out/Aux – the connector for outputting digital streams / auxiliary input
- Control – the connector of the External Control Terminal (Ethernet)
- PTP – the input/output sync connector (according to PTPv2 protocol)
- CTCS, Current – the terminal for connecting the external switchgear unit CTCS (for calibration of conventional CTs)
- PPS in /PPS out – the input/output sync connector (1 PPS)
- Fout – the frequency output (TM and TTL)
- CLKout /CLKin – the input/output connector 5/10/20 MHz
- Fin – the frequency input
- SH, USB – service connectors

**Fig. 2.2** – Portable version (input and output terminals)

## **2.4 Design and operation principle**

The operation is based on the analogue-to-digital conversion of input instantaneous values into digital codes from which the arrays of sampled instantaneous current and voltage values are created. The values of measured parameters are calculated from the arrays according to the algorithms implemented in the firmware.

### **2.4.1 Basic functional modules**

- Measurement Unit
- External Control Terminal based on a PC, laptop computer, or tablet

The Measurement Unit consists of:

- Multi-range converters of input current
- Multi-range converters of input voltage
- 8-channel ADC
- Control module based on a built-in single-board computer
- Wi-Fi access point
- Ethernet switch
- Synchronization unit
- Power supply unit

The Multi-range converters of input current built on electronically compensated measuring current transformers provide the conversion of input current waveforms into proportional voltage signals.

The Multi-range converters of input voltage built on 4 precision variable-gain inverting operational amplifiers provide scaling conversion of input voltage waveforms.

The 8-channel ADC module comprises 8 ADC chips that convert the signals from the multi-range converters (or from the external switchgear unit CTCS) into 18-bit digital codes (the sign bit is the first).

The Control module running on the Intel processor based built-in signal board computer receives, processes (including mathematical computations) and transmits data via Ethernet or Wi-Fi to the External Control Terminal.

The Wi-Fi access point connects the instrument with the External Control Terminal via Wi-Fi.

The Ethernet Switch connects the instrument with the External Control Terminal and external devices via Ethernet.

The Synchronization unit provides internal and external synchronization.

The External Control Terminal controls entire operation of the instrument. It is responsible for its configuration, data representation and generation/export of test reports.

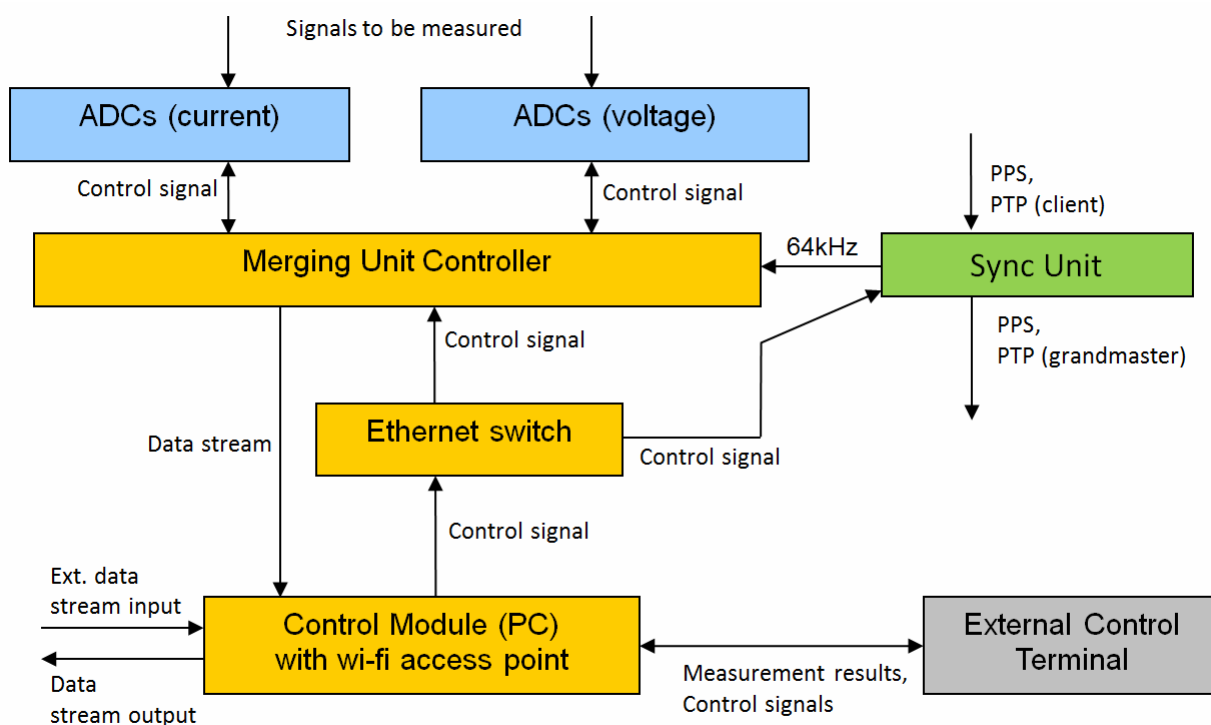

Fig. 2.3 – Functional block diagram

### 2.4.2 Synchronization Unit

The Synchronization Unit automatically scans the input connectors of the instrument for the presence of an external synchronization signal 1Hz (PPS).

In the present version of the instrument, there are 2 modes of synchronization: internal (with an internal quartz generator) and external PPS (with an external PPS signal). The sync modes are selected in the program EnergoMonitor-61850EXT.

**Note! If in the EnergoMonitor-61850EXT, the synchronization mode is set to external PPS, but in fact no sync signal is applied to the input from an external source, readings in the tabs will not be updated, and Stream 61850 will not be present. To correct the situation, it is necessary to take one of the following measures:**

- Set the internal synchronization mode in the program: Settings → Synchronization → Internal (quartz generator)
- Apply a PPS sync signal to the corresponding input.

When a sync sequence is active, the LED (labeled PPS) flashes to indicate the presence of the sync signal.

The connectors on the Sync Unit are divided into 3 sets:

1. Set of input connectors (PPS in, CLK in, and F in) used to connect external synchronization sources
2. Set of output connectors (PPS out, CLK out, F out - TM, F out - TTL) used to synchronize external devices from the Sync Unit
3. Connector PTP used to either synchronize external devices (the Grandmaster Clock mode) or provide synchronization from an external server using the Precision Time Protocol (PTP) (reserved for future versions)
4. The 1<sup>st</sup> set (input connectors):
  - PPS in – accepts PPS signal (1 Hz)



- CLK in – accepts 5/10/20 MHz signal (reserved for future versions)
- F in – frequency input

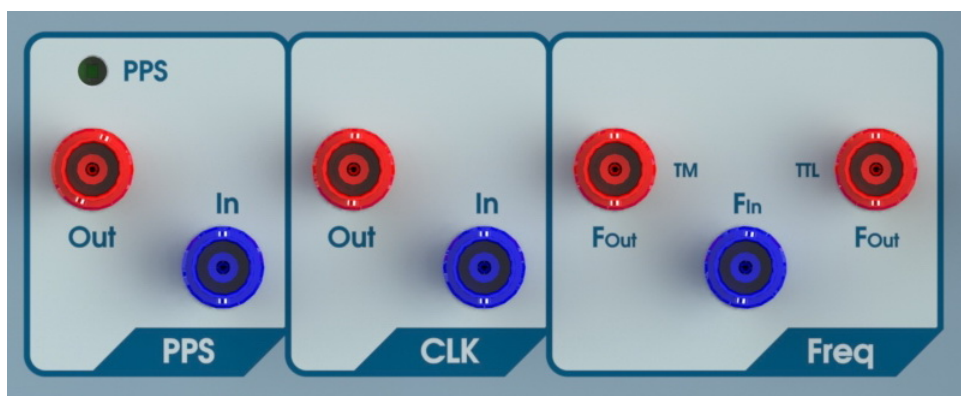

**Fig. 2.4** – Sets of input and output connectors

The input connectors are used to connect the instrument with external sources of synchronization (radio clocks, generators etc.).

The 2<sup>nd</sup> set (output connectors):

- PPS out – the PPS (1 Hz) signal output
- CLK out – the 5/10/20 MHz signal output (reserved for future versions)
- Fout - TM, Fout - TTL – the frequency outputs

The output connectors are used to send sync signals to the external devices (Merging Units under test, generators etc.).

The 3<sup>rd</sup> set (PTP connector, see Fig. 2.5)

The PTP connector is used to either synchronize external devices (the Grandmaster Clock mode) or provide synchronization from an external server using the Precision Time Protocol (PTP) (reserved for future versions).

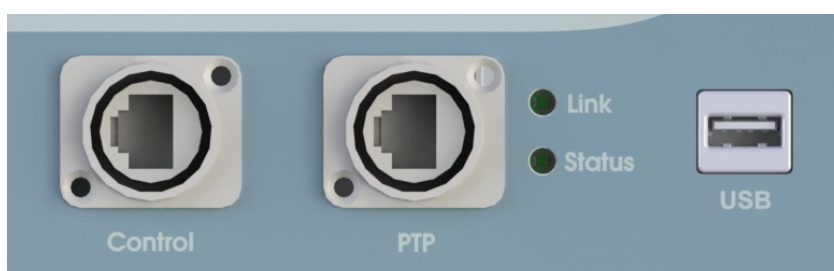

**Fig. 2.5**

The connectors Ext, Out/Aux, Control, and PTP can be connected through the built-in Ethernet switch, Control Terminal, or external devices (with respect to the EM-61850) via Ethernet.

### 2.4.3 Interface of the External Control Terminal

The interface of the External Control Terminal (the Program interface below) is represented as a set of screens, dialog boxes, menus, and controls. The interface elements are navigated with a keyboard, mouse, and touchpad.

The Program interface is described in the EnergoMonitor-61850EXT User Manual.

### 3. Preparing for operation

#### 3.1. Notes on operating conditions

3.1.1 **Caution!** If the instrument has been moved from a cold environment (with ambient temperature below minus 5° C) into a warm one, it shall be left to stand for at least 4 hours at room temperature before applying power, to make sure that no condensation remains inside.

**Caution!** The instrument shall not be used under the ingress of moisture inside its body.

3.1.2 Operating conditions:

Ambient temperature .....	23 ±5 °C
Operating temperature range .....	5 to 40 °C
Relative humidity, %.....	up to 90 at 25 °C
Atmospheric pressure .....	537 – 800 mm Hg (70 – 106.7 kPa)

3.1.3 **Caution!** The amplitude values of voltages and currents applied to the measuring inputs of the EM-61850 must not exceed 170% of the rated values of voltage and current stated for the instrument (150% if the rated value of voltage is 800V).

3.1.4 The EM61850 is controlled via the Program interface (installed on a PC, laptop, or tablet) using the tools provided by the operating system.

#### 3.2. Unpacking

Check that the delivery package contains all parts specified in the Supply Agreement. Check to see if the manufacturer's seal is intact. Should anything in the package be found damaged, contact the supplier immediately.

#### 3.3. Making connections

##### **Warning!**

**To avoid electric shock, it is strongly recommended to connect (disconnect) the EM-61850 to the measured circuits when they are de-energized. Otherwise, connection (disconnection) to the measured circuits shall be carried out by qualified service personnel in compliance with local safety regulations in force.**

Before making connections, inspect the cables. Ensure all joints are made properly to avoid overheating and excessively high resistance.

The EM-61850 has voltage input connectors (phase and neutral) and current input connectors. The phase current inputs are galvanically isolated from each other and from the voltage inputs.

Current signals up to 12A and current signals up to 120A are connected through the different currents inputs. You must use the proper cables from the delivery package for connection.

If the Measuring Unit communicates with the Control Terminal via WiFi, the WiFi antenna should be installed on the Measuring Unit.

If the Measuring Unit communicates with the Control Terminal via Ethernet, use the Ethernet cable.

## 4. Operation

### 4.1. Turning on

On applying power, the power indicator turns on. The EM-61850 performs self-testing and initialization for several seconds after starting up, which is indicated by short beeps.

In addition, when it is powered up, the instrument switches its relays for testing purposes which is manifested by specific clicks.

The instrument is considered to be finally ready to perform stable operation in 30 min after applying power.

**Note:** *the operator interface may be changed with respect to the form and order of displaying information. These changes do not affect the performance and accuracy characteristics of the instrument.*

### 4.2. Configuring the instrument

The EM-61850 is configured and operated via the Control Terminal in the EnergoMonitor-61850EXT program (see Chapter 3 – “Operating the Program” of the EnergoMonitor-61850EXT user manual).

### 4.3 Verification of conventional voltage transformers

#### General

See also Section 3.5 – “Transformers” of the EnergoMonitor-61850EXT user manual.

The mode provides for performance and accuracy testing of instrument voltage transformers (VTs). In this mode, the EM-61850 works as a comparator.

The accuracy class of transformers under test should be 0.02 (or worse). Test reports are recorded into the terminal client memory as \*.rtf files.

The following units are included in the VT test set (Fig. 4.1):

- Adjustable HV source
- Reference VT
- VT burden set
- Reference meter EM-61850

The Adjustable HV source generates voltage applied to the primary (high-voltage) inputs of the reference VT and VT under test.

The secondary windings of the reference VT and VT under test are connected to the phase voltage inputs  $U_B$  and  $U_A$  of the EM-61850 (Potential input) respectively. The neutral terminals of the secondary (low voltage) windings of the reference VT and VT under test are connected to the “Un” connector of the EM-61850 (Potential input). The burden set is connected to the VT under test with separate cables.

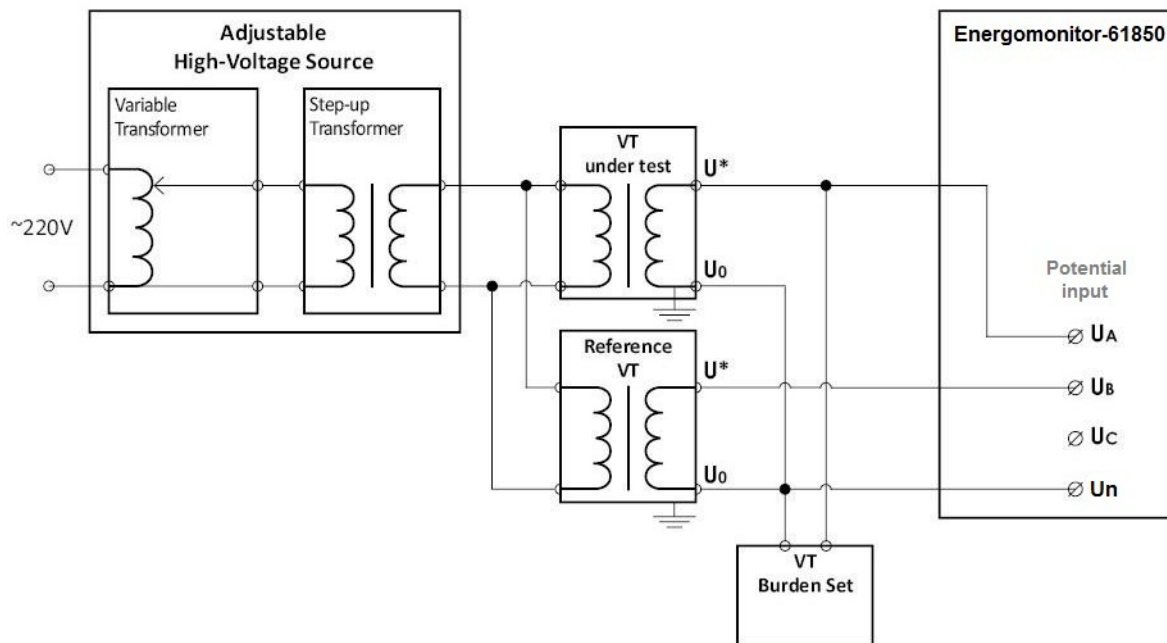

**Fig. 4.1 – VT test connection diagram**

### Setting up VT data

Before starting a test procedure, it is necessary to specify the parameters of the VT under test in the “Specification” tab.

In the fields you can specify the type, serial number, and year of manufacture of the VT under test as well as its accuracy class, rated frequency (Hz), rated primary (kV) and secondary (V) voltages, rated apparent power (VA), and the name of the location.

Any test procedure is carried out in 2 steps:

1. Zero correction (compensation of the differences in characteristics of the voltage measurement channels)
2. Verification

### Zero correction

Zero correction shall be carried out in 30 min (or later) after applying power to the EM-61850.

**Note! Prior to starting Zero Correction make sure that the measurement range set in the EM-61850 is no less than the nominal (rated) value of the secondary of the reference transformer.  
Zero Correction should be repeated each time after a measurement range has been changed.**

To start zero correction, select the **Zero Correction** option of the “VT” tab. Apply the required test voltage from the Adjustable voltage source to the primaries of the reference VT and VT under test.

At this time, the voltage from the secondary winding of the reference VT is applied to the phase voltage inputs  $U_A$  and  $U_B$  of the EM-61850. The EM-61850 will carry out zero correction, namely it will electronically compensate both amplitude and phase shift differences between voltages in channels A and B.

To obtain the highest possible measurement accuracy, it is recommended to carry out zero correction after a considerable (greater than 5 °C) drop in ambient temperature and after each changing of measurement range.

### Verification

Before starting the procedure, it is necessary to select the value of test burden for the tested and reference transformers (expressed in the values of apparent power, VA). This value should be specified in the “Load” field of the “Verification” tab.

### 4.4 Verification of conventional current transformers

The mode provides for performance and accuracy testing of conventional instrument current transformers (CTs). In this mode, the EM-61850 works as a comparator. Verification may be carried out either with use of the auxiliary Current Transformer Calibration Switch CTCS (see Fig. 4.2a) or without it. CTCS is an auxiliary device that provides quick and safe connections among the transformer secondary windings, comparator and burden.



Fig. 4.2a

The current from the secondary winding of the reference CT is applied to the input  $I_B$ , and the current from the CT under test secondary is applied to the input  $I_A$  of the EM-61850.

The EM-61850 supports calibration of CTs rated at 1A and 5A.

The accuracy class of transformers under test should be 0.02 (or worse). Test reports are recorded into the terminal client memory as \*.rtf files.

The following units are included in the CT test set (Fig. 6.1):

- Adjustable current source
- Reference CT
- CT burden set
- Reference meter Energomonitor-61850 complete with CTCS

The Adjustable current source generates current passing through the primary windings of the reference CT and CT under test.

The secondary windings of the reference CT and CT under test are connected to the corresponding input terminals of the CTCS. The burden set is connected to the corresponding terminals of the CTCS.

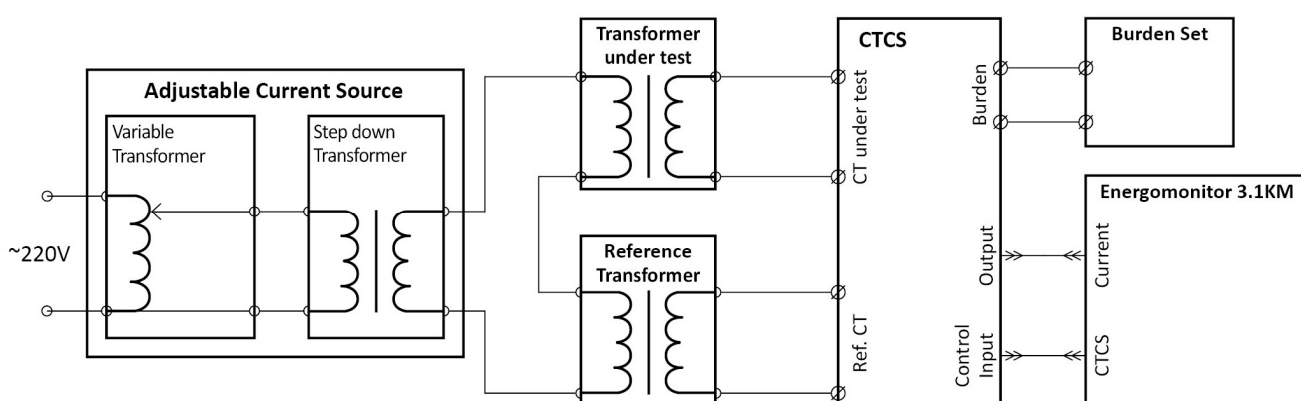

**Fig. 4.2b** – CT test connection diagram

The next steps are in full correspondence with the ones described for conventional VTs.

#### **4.5. Verification of digital voltage transformers**

The mode provides for performance and accuracy testing of instrument voltage transformers (VTs) with IEC 61850-9-2 digital outputs. In this mode, the EM-61850 works as a comparator.

See section Transformers of the EnergoMonitor-61850EXT user manual.

Test reports are recorded in the memory of the control terminal as \*.rtf files.

##### **4.5.1 Comparing a 61850-9-2 signal from the VT under test with an analogue signal from the reference transformer**

In this mode, the VT under test output is connected to the ‘Ext’ input of the EM-61850 via a SFP-RJ45 or SFP-SX adapter. The secondary (low voltage) winding of the reference VT is connected to the inputs  $U_B$  and  $U_n$  of the EM-61850 (Potential input).

The other steps are in full correspondence with the ones described for conventional transformers (considering that zero correction is not needed).

**Note! A standard optical SFP-adapter may not provide the connection between any optical transformer under test and the EM61850 by the reason of incompatibility.**

Thus, to provide the connection between a transformer under test with an optical output and the EM-61850, it is recommended to use an Ethernet-Fiber media converter chosen to suit the characteristics of the optical output of the tested transformer.

When deciding on a particular model of the media converter, the parameters to be considered are the optical connector type and the number of fiber modes (single-mode or multi-mode). For example, a converter by Moxa ([Moxa IMC-21-M-SC](#), a multi-mode SC-connector) may be recommended.

#### **4.6. Verification of digital current transformers**

The mode provides for performance and accuracy testing of instrument current transformers (CTs) with IEC 61850-9-2 digital outputs. In this mode, the EM-61850 works as a comparator.

See section Transformers of the EnergoMonitor-61850EXT user manual.

Test reports are recorded in the memory of the control terminal as \*.rtf files.

##### **4.6.1 Comparing a 61850-9-2 signal from the CT under test with an analogue signal from the reference transformer**

In this mode, the CT under test output is connected to the “Ext” input of the EM-61850 via a SFP-RJ45 or SFP-SX adapter. The output of the reference transformer is connected to the A input of the EM-61850 (“Current input” terminals, 12A input).

The other steps are in full correspondence with the ones described for conventional transformers (considering that zero correction is not needed).

**Note!** A standard optical SFP-adapter may not provide the connection between any optical transformer under test and the EM61850 by the reason of incompatibility.

Thus, to provide the connection between a transformer under test with an optical output and the EM-61850, it is recommended to use an Ethernet-Fiber media converter chosen to suit the characteristics of the optical output of the tested transformer.

When deciding on a particular model of the media converter, the parameters to be considered are the optical connector type and the number of fiber modes (single-mode or multi-mode). For example, a converter by Moxa ([Moxa IMC-21-M-SC](#)), a multi-mode SC-connector) may be recommended.

## Specifications

Basic metrological (accuracy) specifications of EM61850 (accuracy class 0.2) are listed in Tables 3.1 – 3.2.

EM61850 measures electrical parameters with the accuracy characteristics stated below, provided that the amplitude values of measured voltages and currents do not exceed:

- 170% of the rated (nominal) values of measurement ranges ( $U_N$  and  $I_N$  respectively)
- 150% of the rated value if the measurement range is 800V.

Table A.1 – Accuracy characteristics of Energomonitor-61850 x-02-xx

Measured parameter	Measurement range	Type and limits of permissible intrinsic measurement error	Notes
1	2	3	4
RMS of AC voltage and RMS of fundamental voltage harmonic $U$ and $U_{(1)}$ , V	$0.1 \cdot U_N$ to $1.2 \cdot U_N$	relative, % $\pm[0.01+0.002 \cdot (1.2 \cdot U_N/U-1)]$	$U_N > 2$ V
		relative, % $\pm[0.015+0.003 \cdot (1.2 \cdot U_N/U-1)]$	$U_N \leq 2$ V
RMS of AC current and RMS of fundamental current harmonic $I$ and $I_{(1)}$ , A	$0.1 \cdot I_N$ to $1.2 \cdot I_N$	relative, % $\pm[0.01+0.002 \cdot (1.2 \cdot I_N/I-1)]$	$I_N \leq 10$ A
		relative, % $\pm[0.025+0.002 \cdot (1.2 \cdot I_N/I-1)]$	$I_N > 10$ A
Active power and active power of fundamental harmonic ( $P$ and $P_{(1)}$ ), W	$0.1 \cdot I_N$ to $1.2 \cdot I_N$ $0.1 \cdot U_N$ to $1.2 \cdot U_N$	relative, % $\pm[0.01+0.004 \cdot (P_N/P-1)]$	$P_N = U_N \cdot I_N$ $ \cos \phi : 0.9$ to $1.0$ $U_N > 2$ V $I_N \leq 10$ A
		relative, % $\pm[0.025+0.004 \cdot (P_N/P-1)]$	$ \cos \phi : 0.9$ to $1.0$ $U_N > 2$ V $I_N > 10$ A
		relative, % $\pm[0.025+0.004 \cdot (1.44 \cdot P_N/P-1)]$	$ \cos \phi : 0.9$ to $1.0$ $U_N \leq 2$ V $I_N \leq 10$ A
		relative, % $\pm[0.015+0.004 \cdot (1.44 \cdot P_N/P-1)]$	$ \cos \phi : 0.2$ to $0.9$ $U_N > 2$ V $I_N \leq 10$ A
		relative, % $\pm[0.05+0.01 \cdot (1.44 \cdot P_N/P-1)]$	$ \cos \phi : 0.2$ to $0.9$ $U_N \leq 2$ V or (and) $I_N > 10$ A
Apparent power (S), VA	$0.1 I_N$ to $1.2 I_N$ $0.1 U_N$ to $1.2 U_N$	relative, % $\pm[0.02+0.005 \cdot (1.2 \cdot U_N/U+1.2 \cdot I_N/I-2)]$	$U_N > 2$ V $I_N \leq 10$ A
		relative, % $\pm[0.04+0.01 \cdot (1.2 \cdot U_N/U+1.2 \cdot I_N/I-2)]$	$U_N \leq 2$ V or (and) $I_N > 10$ A
Reactive power calculated by geometrical method (Q), Var ( $Q_N = U_N \cdot I_N$ )	$0.1 I_N$ to $1.2 I_N$ $0.1 U_N$ to $1.2 U_N$	relative, % $\pm[0.03+0.01 \cdot (1.44 \cdot Q_N/Q-1)]$	$U: 0.1 U_N$ to $1.2 U_N$ $I: 0.1 I_N$ to $1.2 I_N$ $ \sin \phi : 0.9$ to $1.0$
		relative, % $\pm[0.05+0.01 \cdot (1.44 \cdot Q_N/Q-1)]$	$ \sin \phi : 0.2$ to $0.9$



Measured parameter	Measurement range	Type and limits of permissible intrinsic measurement error	Notes
Reactive power of fundamental harmonic ( $Q_1$ ), Var	0.1I <sub>N</sub> to 1.2I <sub>N</sub> 0.1U <sub>N</sub> to 1.2U <sub>N</sub>	relative, %, $\pm[0.03+0.01 \cdot (1.44 \cdot Q_N/Q_1-1)]$	U: 0.1U <sub>N</sub> to 1.2U <sub>N</sub> I: 0.1·I <sub>N</sub> to 1.2·I <sub>N</sub>  sin φ : 0.9 to 1
		relative, % $\pm[0.05+0.01 \cdot (1.44 \cdot Q_N/Q_1-1)]$	sin φ : 0.2 to 0.9
AC frequency ( $f_1$ ), Hz	40 to 70	absolute, Hz $\pm 0.0002$	0.1I <sub>N</sub> to 1.2I <sub>N</sub> 0.1U <sub>N</sub> to 1.2U <sub>N</sub>
Phase angle between fundamental harmonics of:	0 to 360	Absolute, degrees $\pm 0.003$	0.1U <sub>N</sub> to 1.2U <sub>N</sub>
- Input voltages		absolute, degrees $\pm 0.003$	
- Voltage and current in the same phase			0.1I <sub>N</sub> to 1.2I <sub>N</sub> 0.1U <sub>N</sub> to 1.2U <sub>N</sub>
Total Harmonic Distortion of voltage (THD <sub>U</sub> ), % (U: 0.2U <sub>N</sub> to 1.2U <sub>N</sub> )	0 to 50	absolute, % $\pm 0.01$	THD <sub>U</sub> < 1.0
		relative, % $\pm 1$	THD <sub>U</sub> ≥ 1.0
RMS of voltage harmonic of order h* (U <sub>Ch</sub> ) (h = 2 ... 50)	0 to 0.6·U <sub>N</sub>	absolute, V $\pm 0.0001 \cdot U_N$	U <sub>Ch</sub> ≤ 0.01·U <sub>N</sub>
		relative, % $\pm 1$	U <sub>Ch</sub> > 0.01·U <sub>N</sub>
Voltage harmonic of order h (in reference to fundamental harmonic) [K <sub>U</sub> (h)] (h = 2 ... 50)	0 to 49.9	absolute, % $\pm 0.003$	U: 0.2U...1.2U <sub>N</sub> K <sub>U</sub> (h) < 1.0
		relative, % $\pm 0.3$	K <sub>U</sub> (h) ≥ 1.0
Total harmonic distortion of current (THD <sub>I</sub> ), % (I: 0.2·I <sub>N</sub> to 1.2·I <sub>N</sub> )	0 to 50	absolute, % $\pm 0.01$	THD <sub>I</sub> < 1.0
		relative, % $\pm 1.0$	THD <sub>I</sub> ≥ 1.0
RMS of current harmonic of order h (I <sub>Ch</sub> ) (h = 2 ... 50)	0 to 0.6I <sub>N</sub>	absolute, A $\pm 0.0001 \cdot I_N$	I <sub>Ch</sub> ≤ 0.01·I <sub>N</sub>
		relative, % $\pm 1$	I <sub>Ch</sub> > 0.01·I <sub>N</sub>
Current harmonic of order h (in reference to fundamental harmonic) [K <sub>I</sub> (h)] (h = 2...50) (I: 0.2·I <sub>N</sub> to 1.2·I <sub>N</sub> )	0 to 49.9	absolute, % $\pm 0.003$	K <sub>I</sub> (h) < 1.0
		relative, % $\pm 0.3$	K <sub>I</sub> (h) ≥ 1.0
Phase angle between the fundamental of voltage and the 1 Hz reference frequency signal (PPS), degrees	0 to ±180	$\Delta = \pm k_F \cdot f_1$ , where: $k_F = 0.0003$ degree/Hz	0.2·U <sub>N</sub> to 1.2·U <sub>N</sub>

Measured parameter	Measurement range	Type and limits of permissible intrinsic measurement error	Notes
Phase angle between the fundamental of current and the 1 Hz reference frequency signal (PPS), degrees	0 to $\pm 180$	$\Delta = \pm k_F \cdot f_i$ , where $k_F = 0.0003$ degree/Hz	$0.2 \cdot I_N$ to $1.2 \cdot I_N$
Frequency of the reference signal (PPS)	1 Hz	relative, $\pm 2 \cdot 10^{-6}$	
Normal measurement conditions: - Environment temperature, °C - Relative humidity, % - Atmospheric pressure, kPa		+15 to +30 30 to 80 84 to 106.7	
Limits of additional measurement error introduced by environment temperature variations within the operating temperature range, expressed in fractions of permissible intrinsic measurement error		1.0	
Limits of additional measurement error introduced by crosstalk of measurement channels, expressed in fractions of permissible intrinsic measurement error		0.5	

Table A.2 – Accuracy characteristics of Energomonitor-61850 x-02-xx in terms of testing electronic voltage and current transformers with IEC 61850-9-2 outputs

Measured parameter	Measurement range	Type and limits of permissible intrinsic measurement error	Notes
<i>Voltage transformers</i>			
Ratio error ( $\delta U_{VT}$ ), %	-20.0 ... +20.0	$\pm 0.015$	$0.2 \cdot U_N$ to $1.2 \cdot U_N$ $f = (f_N \pm 1)$ Hz
Phase error ( $\Delta \phi_{VT}$ ), '	-180° ... +180°	$\pm 1.0$	
Composite error (the absolute value of the difference between voltage phasors), %	-20.0 to +20.0	$\pm 0.03$	
<i>Current transformers</i>			
Ratio error ( $\delta I_{CT}$ ), %	-20.0 to +20.0	$\pm 0.015$	$0.01 \cdot I_N$ to $1.2 \cdot I_N$ $f = (f_N \pm 1)$ Hz
Phase error ( $\Delta \phi_{CT}$ ), '	-180° to +180°	$\pm 1.0$	
Composite error (the absolute value of the difference between current phasors), %	-20.0 to +20.0	$\pm 0.03$	
Notes			
$U_N$ – rated primary voltage of EVT under test			
$I_N$ – rated primary current of ECT under test			
$f_N$ – rated frequency of EVT or ECT under test (50 or 60 Hz).			

## Appendix B

### Scope of supply

A standard delivery package of EM61850 is specified in Table B.1.

Table B.1 – Standard delivery package

Name	Designation	Q-ty
Multifunctional reference meter Energomonitor-61850 together with Control Terminal (a PC with EnergoMonitor-61850EXT software installed)		1 set
Set of cables		1 set*
User Manual	MC3.055.501 UM	1
Note * See Tables B2 and B3		

A standard set of accessories is specified in Table B.2.

Table B.2 – Standard set of accessories

Name	Designation	Q-ty
Current measurement cable (2-wire), 1m length (up to 12 A )		4
Current measurement cable, 1.5 m length (up to 120 A)		8
Power supply cable (3x0.75, 1.8 m)		1
Voltage measurement cable, 2 m length		5
Ethernet cable, 2 m length (RJ-45 - RJ-45)		1
Note *As specified in the purchase order		

A set of accessories may include the items listed in Table B.3 as specified in the Supply Agreement.

Table B.3 – Set of optional accessories

Name	Designation	Q-ty *	Notes
Current Transformer Calibration Switch CTCS (provides commutation among the units of the test scheme), 3 pcs		3	For Energomonitor -61850 x-xx-01
WiFi antenna		1	
SFP-optical adapter LC		2	
Patch cord duplex LC/UPC-SC/UPC, MM 50/125		1	1m
Patch cord duplex LC/UPC-LC/UPC, MM 50/125		1	1m
SFP-Ethernet adapter		2	
Cable BNC-BNC, blue, 2 m, XLSS-58	67.9770-200.23	1	High-frequency
Cable BNC-BNC, red, 2 m, XLSS-58	67.9770-200.22	1	High-frequency
Insulated signal distributor XM-FF	67.9783-21	1	1BNC(M)-2BNC(F)

MARS-ENERGO

<b>Name</b>	<b>Designation</b>	<b>Q-ty *</b>	<b>Notes</b>
Insulated signal coupler XF-F	67.9547-28	1	BNC(F)-BNC(F)
Jumper KS4-19L/1	24.0027-21	1	2 bannan (M)-2 bannan (F)
Ø 4 MM / BNC adapter lead XLAM-446/SC/SIL	67.9868-160	1	BNC-2 bannan (M)
Note * The quantity is subject to change upon request			